

APPLICABLE STANDARD					
RATING	OPERATING TEMPERATURE RANGE	-35°C TO +85°C (NOTES 1)	STORAGE TEMPERATURE RANGE	-10°C TO +60°C	
	VOLTAGE	30V AC	APPLICABLE CONNECTOR	BM10*(0.8)-44DP-0.4V(*)	
	CURRENT	0.3A			
SPECIFICATIONS					
ITEM	TEST METHOD		REQUIREMENTS	QT	AT
CONSTRUCTION					
GENERAL EXAMINATION	CONFIRMED VISUALLY AND BY MEASURING INSTRUMENT.		ACCORDING TO DRAWING.	X	X
MARKING	CONFIRMED VISUALLY.			X	X
ELECTRIC CHARACTERISTICS					
CONTACT RESISTANCE	20mV AC OR LESS 1kHz, 1mA.		100mΩ MAX.	X	-
INSULATION RESISTANCE	100V DC.		50MΩ MIN.	X	-
VOLTAGE PROOF	100V AC FOR 1 min.		NO FLASHOVER OR BREAKDOWN.	X	-
MECHANICAL CHARACTERISTICS					
INSERTION AND WITHDRAWAL FORCES	MEASURED BY APPLICABLE CONNECTOR.		INSERTION FORCE 45.4N MAX WITHDRAWAL FORCE 8.7N MIN	X	-
MECHANICAL OPERATION	10 TIMES INSERTIONS AND WITHDRAWAL.		① CONTACT RESISTANCE: 100mΩ MAX. ② NO DAMAGE, CRACK OR LOOSENESS OF PARTS.	X	-
VIBRATION	FREQUENCY 10 TO 55 TO 10 Hz, APPROX 5min, SINGLE AMPLITUDE 0.75 mm, 10CYCLES, FOR 3 DIRECTIONS.		① NO ELECTRICAL DISCONTINUITY OF 1 μs. ② NO DAMAGE, CRACK OR LOOSENESS OF PARTS.	X	-
SHOCK	490 m/s ² DURATION OF PULSE 11 ms AT 3 TIMES FOR 3 DIRECTIONS.		① NO ELECTRICAL DISCONTINUITY OF 1 μs. ② NO DAMAGE, CRACK OR LOOSENESS OF PARTS.	X	-
ENVIRONMENTAL CHARACTERISTICS					
RAPID CHANGE OF TEMPERATURE	TEMPERATURE -55 → +85 °C TIME 30 → 30 min UNDER 5 CYCLES. (RELOCATION TIME TO CHAMBER: WITHIN 2 ~3 MIN)		① CONTACT RESISTANCE: 100mΩ MAX. ② INSULATION RESISTANCE: 50MΩ MIN. ③ NO DAMAGE, CRACK OR LOOSENESS OF PARTS.	X	-
DAMP HEAT (STEADY STATE)	EXPOSED AT 40 ± 2 °C, 90 TO 95 %, 96 h.		① CONTACT RESISTANCE: 100mΩ MAX. ② INSULATION RESISTANCE: 25MΩ MIN. ③ NO DAMAGE, CRACK OR LOOSENESS OF PARTS.	X	-
SULPHUR DIOXIDE	EXPOSED IN 25 PPM FOR 96h, 25°C, 75%. (REFER TO JIS C 60068)		① CONTACT RESISTANCE: 100mΩ MAX. ② NO DAMAGE, CRACK OR LOOSENESS OF PARTS.	X	-
COUNT	DESCRIPTION OF REVISIONS	DESIGNED	CHECKED	DATE	
△					
REMARKS			APPROVED	KH. IKEDA	10.01.05
NOTE1: INCLUDE THE TEMPERATURE RISING BY CURRENT			CHECKED	TS. MIYAZAKI	10.01.05
Unless otherwise specified, refer to JIS C 5402 and IEC 60512			DESIGNED	SH. HOSODA	10.01.04
			DRAWN	SH. HOSODA	10.01.04
Note QT:Qualification Test AT:Assurance Test X:Applicable Test			DRAWING NO.		ELC4-318886-01
HRS	SPECIFICATION SHEET		PART NO.	BM10NB(0.8)-44DS-0.4V(51)	
	HIROSE ELECTRIC CO., LTD.		CODE NO.	CL684-6109-5-51	△ 1/1

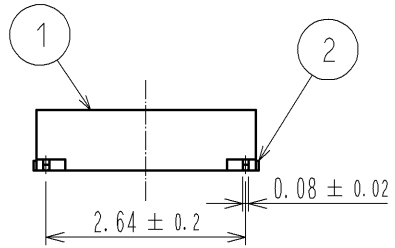

RECOMMENDED PATTERN

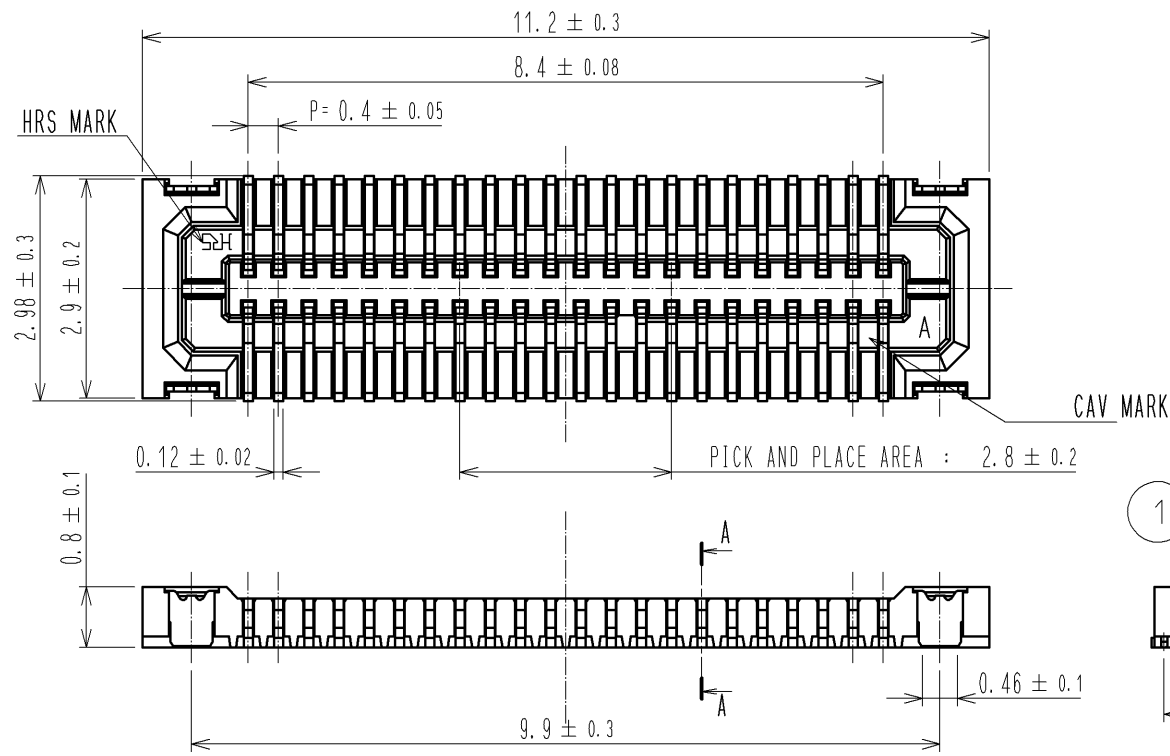
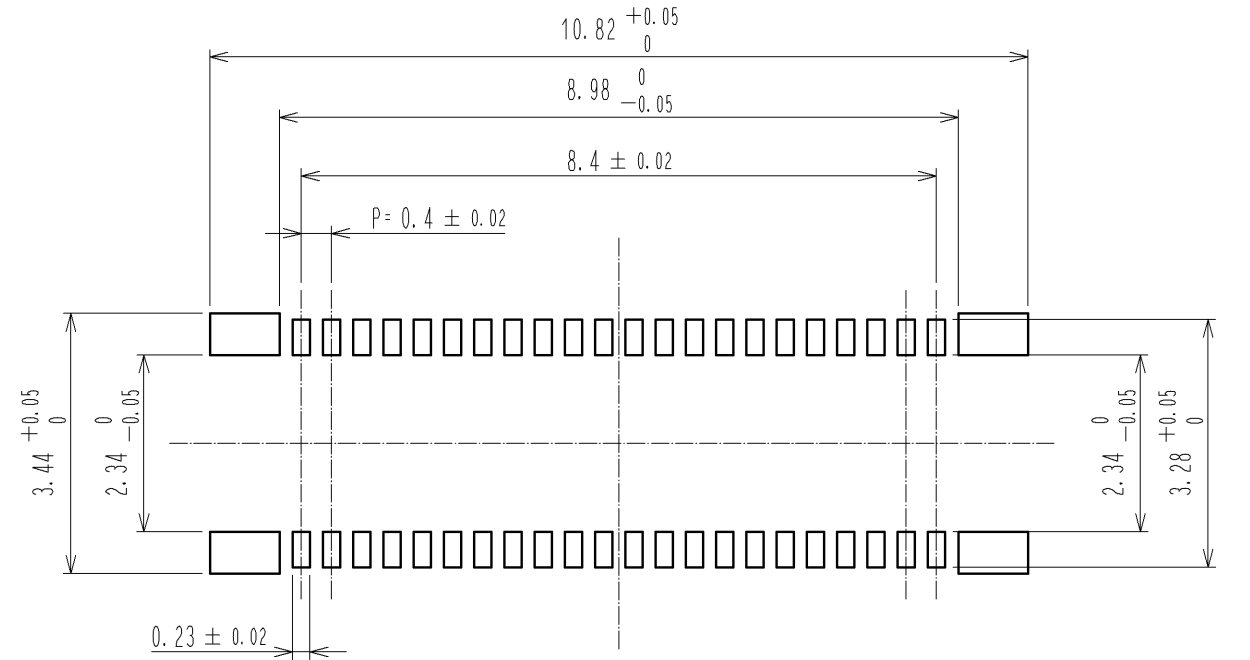

RECOMMENDED SOLDER PASTE: THICKNESS 120#m

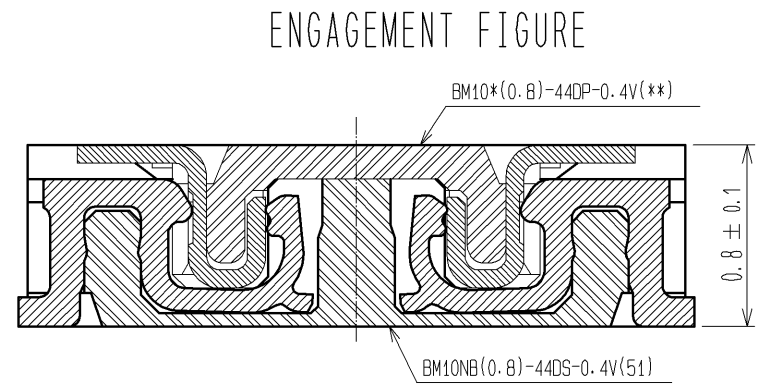
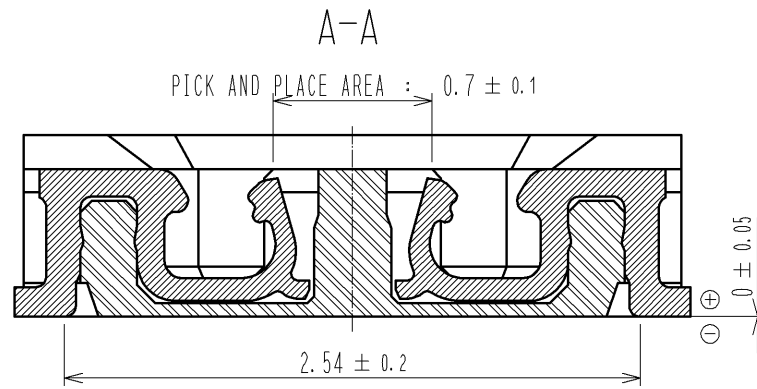
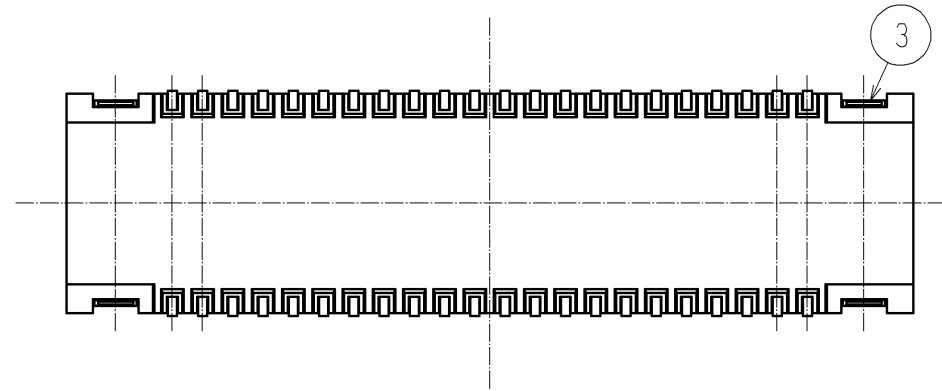

- NOTE 1. ALL LEADS CO-PLANARITY SHALL BE 0.1 MAX.
 2. PER REEL : 8000 CONNECTORS.
 3. AT THE BEGINNING OF THE REEL, 100 mm AT MIN SHALL BE EMPTY POCKETS.
 AT THE END OF THE REEL, 160 mm AT MIN SHALL BE EMPTY.
 4 CONTACT PLATING SPECIFICATIONS.
 CONTACT AREA : GOLD 0.05#m MIN.
 SMT LEAD : GOLD 0.05#m MIN.
 UNDERPLATING : NICKEL 1#m MIN.
 (SURFACE : SEALING)
 5 METAL HOLD DOWN PLATING SPECIFICATIONS.
 MOUNTING AREA: GOLD 0.05#m MIN.
 UNDERPLATING : NICKEL 1#m MIN.
 6. PEEL FORCE OF COVER TAPE REFERS TO JIS C 0806.

3	PHOSPHOR BRONZE	5	6	PS	PLASTIC REEL (BLACK)
2	PHOSPHOR BRONZE	4	5	POLYESTER	CLEAR (COVER TAPE)
1	LCP	UL94V-0. BLACK	4	PS	CLEAR (EMBOSSED CARRIER TAPE)
NO.	MATERIAL	FINISH . REMARKS	NO.	MATERIAL	FINISH . REMARKS
UNITS		SCALE	COUNT	DESCRIPTION OF REVISIONS	
mm		FREE		DESIGNED	CHECKED
APPROVED : KH. IKEDA		10.01.06	DRAWING NO. EDC3-318886-01		
CHECED : TS. MIYAZAKI		10.01.06	PART NO. BM10NB(0.8)-44DS-0.4V(51)		
DESIGNED : SH. HOSODA		10.01.04	CODE NO. CL684-6109-5-51		
DRAWN : SH. HOSODA		10.01.04	1/2		

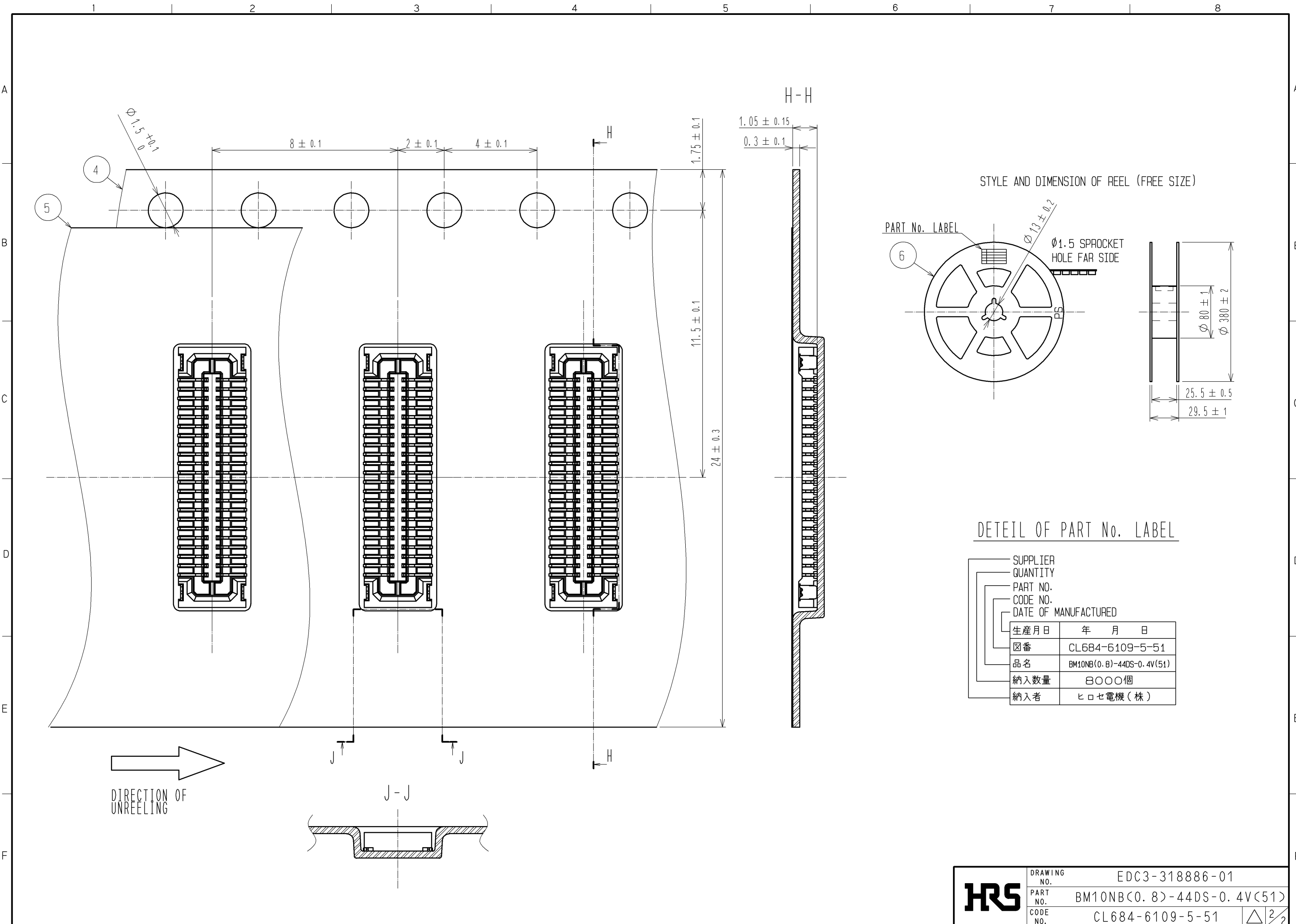

STYLE AND DIMENSION OF REEL (FREE SIZE)

DETEIL OF PART No. LABEL

SUPPLIER	
QUANTITY	
PART NO.	
CODE NO.	
DATE OF MANUFACTURED	
生産月日	年 月 日
図番	CL684-6109-5-51
品名	BM10NB(0.8)-44DS-0.4V(51)
納入数量	8000個
納入者	ヒロセ電機(株)

HRS	DRAWING NO.	EDC3-318886-01	
	PART NO.	BM10NB(0.8)-44DS-0.4V(51)	
	CODE NO.	CL684-6109-5-51	$\triangle 2/2$
	FORM NO.		